

Please indicate the units for all measures

Seller Information

Company:

Contact Name:

Phone Number:

Email Address:

Address: _____

End User Information

Company:

Contact Name:

Phone Number:

Email Address:

Address: _____

The enclosed questionnaire is designed to assist Wulftec in selecting the system which will best meet your present and future requirements. This information will be used as a basis to quote, design and manufacture a system that satisfies your specific application. Please retain a copy for your files. Should there be any changes in requirements or specifications during the course of this project, please contact Wulftec immediately to ensure we are up to date in our understanding of your needs.

Wrapped Product Specifications

Current Product Wrap Method:

Type of Product:

Load Surface Colors:

(Dark or shiny colors require special optional load height detection package)

Individual Product Package: Bags Bottles Cartons Other

Top Layer Configuration

Full Partial Uneven

Stacking Pattern

Column Interlock Random

Load Stability

Can Be Rotated at 16 rpm Yes No

Requires Top Platen Yes No

Other

Requires Integrated Scale Yes No

Loading / Unloading

Forklift Forklift & Pallet Jack¹

Pallet Jack¹

Other:

1- Electric pallet jacks or pallet jacks with long forks may require ramp extensions. Please complete our "Pallet Jack Survey"

Please indicate the units for all measures

Load Specifications
Load Profile

Maximum Load Inboard / Overhang from Pallet Edges

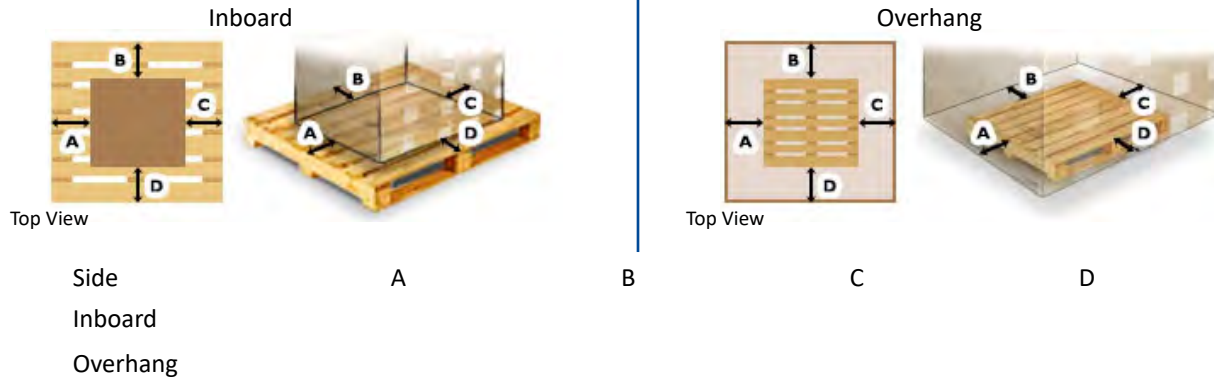

Load Puncture Hazard Profile

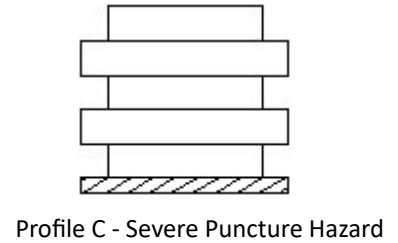
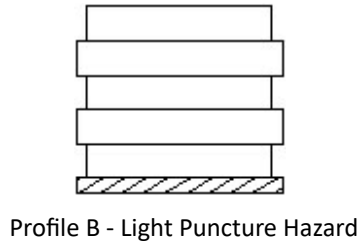
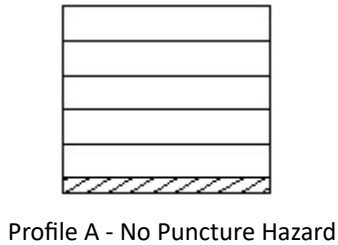

Pallet Type



Winged

No Wings

New

Used

Reconditioned

Wood

Plastic

Load Size

	Length	Width	Height (including pallet)	Weight	% of production
Maximum					
Average					
Minimum					

Production Rate & Carriage Info

Production Rate	Normal	Peak	Future	# of Top Wraps:
Load per hour				# of Bottom Wraps:

Web Overwrap [over top of load]: _____ Web Overlap [during spiral]: _____

Select required pre-stretch ratio: 200%

50%	75%	100%	125%	150%	175%	225%	250%	275%	300%
-----	-----	------	------	------	------	------	------	------	------

Carriage size: 20" / 500mm 30" / 750mm

Film Type: Standard One side cling Perforated Other

Film Thickness: Wulftec's powered pre-stretch carriage normal film range capacity is 60 gauge (15 micron) to 1.5 mils (38 micron). The carriage can be customized to accept other film gauge.

Wrap Pattern

Item	(Check mark required items)	Description
STANDARD wrap: 2" (50 mm) up from turntable/floor		(Wrap load & part of pallet)
Non std wrap: Wrap load & not pallet		Indicate height from turntable/floor:
Banding Wrap		
Other Wrap Pattern		Describe:
Roping		Sequence:

Large inboard or overhang conditions may impair wrap ability to secure load to pallet.

Comments:

Control Panel

Basic Included in machine price	Standard Allows for some options and minor program changes	Standard Plus Intuitive touch screen interface	Deluxe Intuitive touch screen interface that allows for a full range of options and program changes
---	--	--	---

Type of System

Turntable Style

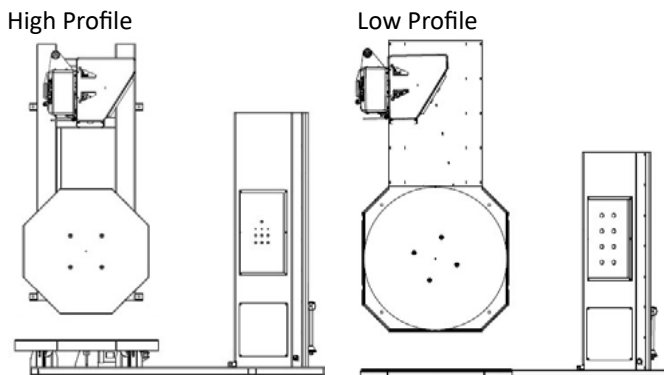

Rotary Arm Style

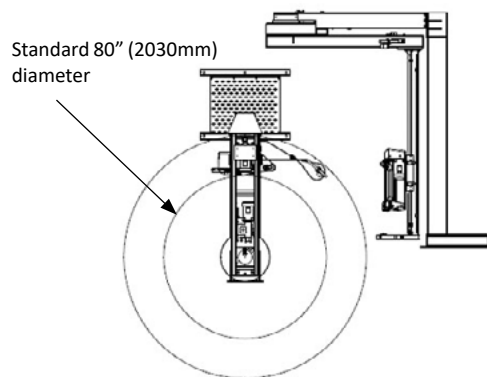

Film Treatment

Requires automated film treatment (Cut & Wipe arm) Yes No

Paint Specification

Machine Color:

Wulftec gray Special paint color Epoxy paint¹ Steel-It paint² Other:
 (Dark gray RAL 7016 (please provide RAL#)
 Light gray RAL 7040)

Environmental Conditions

Wash down area Very Dusty
 Potential corrosives Other:

Temperature Range

Minimum:
 Maximum:
 Typical:

Ceiling Clearance Height:

Power Supply Specifications

Available Power Supply

120VAC / 1ph / 60Hz
 230VAC / 3ph / 60Hz
 Other: VAC / Ph / Hz

Power Source Condition:

Consistent
 Subject to spikes / drops / surges
 Surge protected

1- Epoxy paint is mainly used in wash down applications and in food processing plants.

2- Steel-It paint is mainly used in applications with exposure to ultraviolet rays, chemicals, oils, alkalis, food acid, water immersion, abrasion, and high-pressure wash-downs. Available in gray color only.

Air Supply

Available Compressed Air Supply

3 CFM / 80 PSI (0,08 m³/min / 5,51 bars)¹
 Clean Dry Air
 Other: /

Air Dryer Unit²

Air is clean and dry / no air dryer required
 Air supply needs dryer unit

System Installation & Start Up

Installation

by Manufacturer

by Distributor

Start-up

by Manufacturer

by Distributor

Documentation

(Indicate total number of items required)

for CUSTOMER

for DISTRIBUTOR

User Manual (Include Electrical Schematics)

(Std = 1 printed for Customer)

PPogram Print Out (Non Std)

Additional printed copies of the manual

Copies of manual on USB

Comments:

1- Some options may increase the pneumatic requirements

2- Wulftec provides a Filter / Regulator with all systems that use compressed air.

Air dryers can also be added to remove excess moisture that could damage pneumatic components.